

Wave Series Bifold Door Installation & Maintenance Instructions.

Rev. 10.21

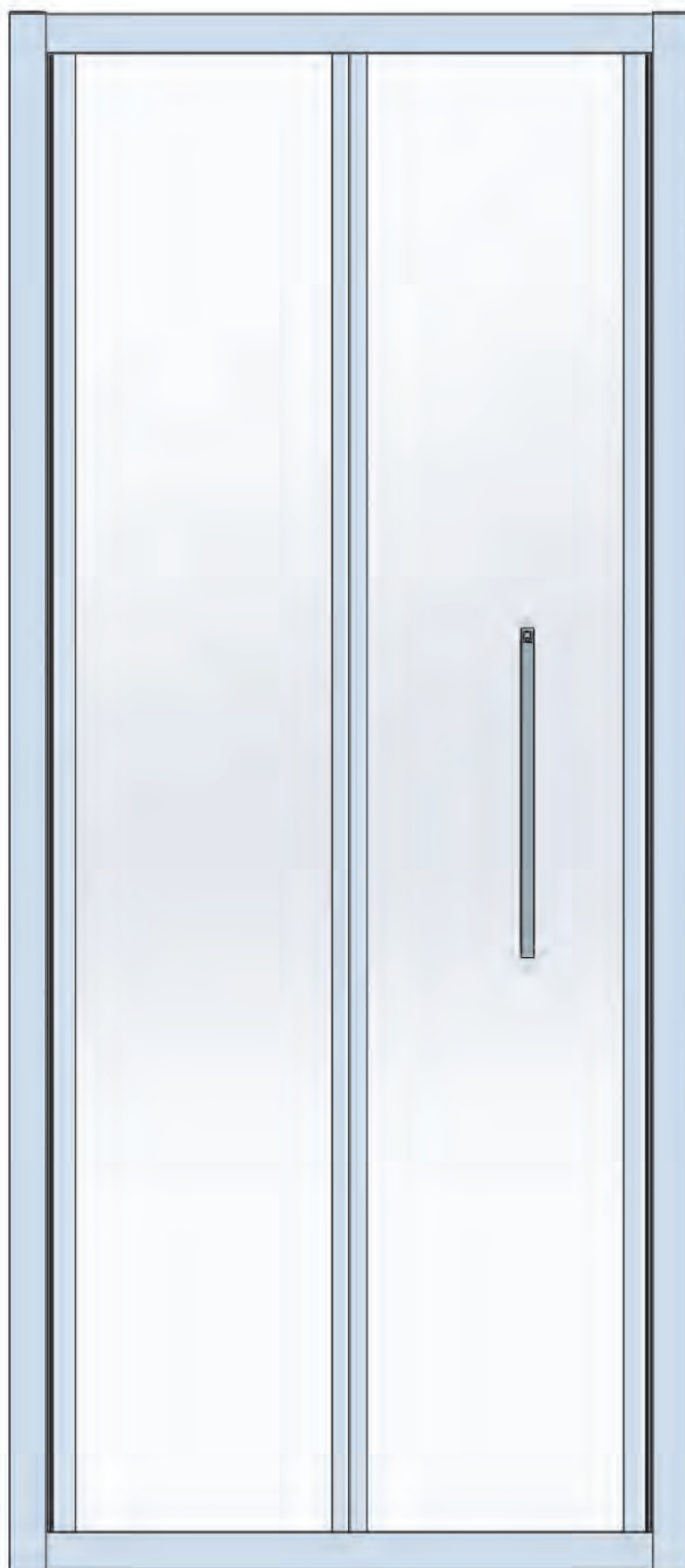

LAKES
SHOWERING SPACES

IMPORTANT NOTES :

Please read carefully & retain these instructions for future reference.

1. For ease & safety we advise that two persons assemble this product.
2. Protect shower tray surface at all times.
3. Exposed glass corners/edges MUST NOT contact hard surfaces at any time.
4. Check for cables, pipes etc. before drilling walls.
5. Ensure all surfaces are dry, clean & free from loose debris or dust.
6. Unpack goods with care (small parts can become lodged in packaging and inadvertently discarded)
Check parts supplied against parts and fittings listed herein.
Damaged parts / omissions may be resolved by calling Lakes helpline.
7. Whilst precautions are taken in manufacture, care must be taken when handling as rail ends may have sharp edges.
8. Before commencing, check that :
 - a) shower tray (if used) is level & completely sealed to finished / tiled walls.
 - b) finished walls are sound and free of cracks, loose tiles / grout.
9. AFTER INSTALLATION DO NOT WET ENCLOSURE FOR 48 HOURS TO ENSURE FULL CURE OF SILICONE SEALANT.

Use :

General Care & Maintenance.

Provided this product is installed and operated in accordance with these instructions problems should not arise however should maintenance be required it should be carried out by a competent person with reference to these instructions. Before any work is carried out, the root cause of the problem must be identified. Lakes service engineers are available if necessary to consult / carry out remedial work. Call Lakes helpline.

Cleaning. (Every one to two weeks depending on local water (hardness) conditions)

All glass panels in this product have a hydrophobic coating which aids "runoff" of water droplets, reducing the need for frequent cleaning however for best appearance & product life regular cleaning is recommended.

Use ONLY mild soap / detergent solutions to clean, rinse with water, squeegee glass panels and wipe frames dry with a soft cloth. Under no circumstances should abrasive, caustic or scouring products be used. Non-compliance with these cleaning instructions may cause decorative finishes to deteriorate & could adversely affect safe operation of the enclosure.

Daily Care.

To prevent the build up of limescale, do not allow water droplets to dry on glass or frames. After showering, rinse with water, remove droplets of water from glass with a squeegee & wipe frame with a soft cloth.

Customer Service.

Quality guarantee : Lakes Bathrooms Ltd. guarantee shower doors and enclosures against any manufacturing or material defects for the lifetime of the product. We will resolve defects free of charge by repairing / replacing parts as we feel necessary. To be free of charge, service work must be carried out by Lakes Bathrooms or approved agents. Seals are considered "wear & tear" parts and as such are guaranteed for 12 months from purchase.

Not covered by this guarantee : Damage or defects that result from improper installation, improper use or lack of maintenance (including limescale buildup). Damage or defects that result from repairs / modifications undertaken by unauthorised persons. This guarantee is in addition to statutory and other legal rights.

What to do if anything goes wrong : Should the product not function correctly on initial use, firstly contact the installer to check that unit installation & commissioning are in accordance with these instructions. Should this not resolve difficulties or should performance decline, consult 'Troubleshooting' section of these instructions to see if simple home maintenance is needed. Alternatively our helpline staff can assist or arrange for a service engineer to visit if necessary.

Spares : We maintain an extensive spare parts stocks. spares can be ordered / purchased from your retailer in the first instance. Parts will normally be despatched within two working days from placement of order.

Parts:

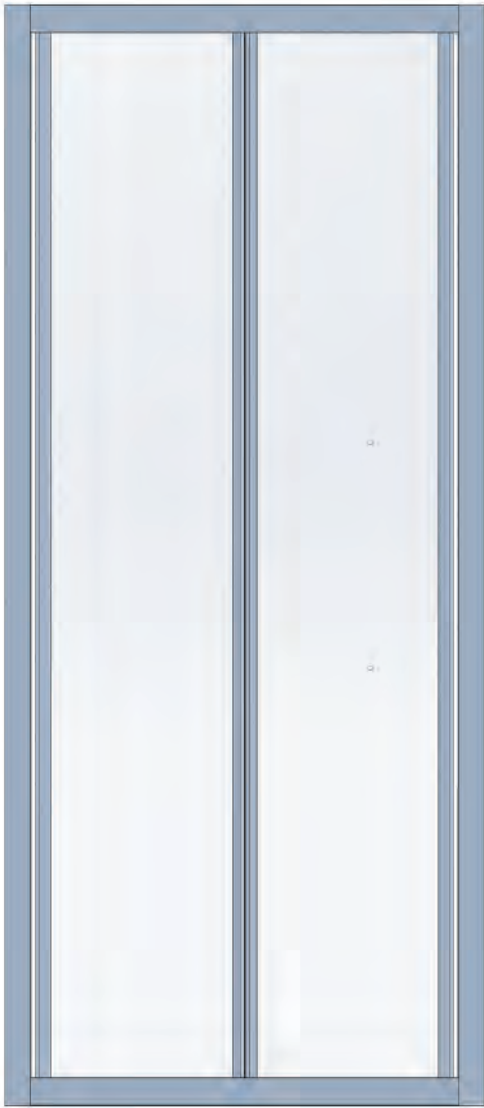

Bifold frame & door assembly



Wall profile assembly x2
(inc. 5 plastic clips)

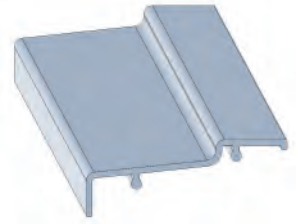

Wall profile cover strip. x2



Handle kit x1

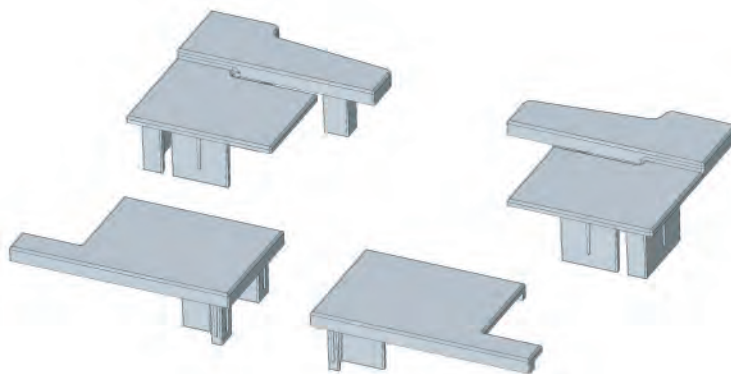

Top cap kit x1



10mm Screw x6



45mm screw x6



Wall plug x6

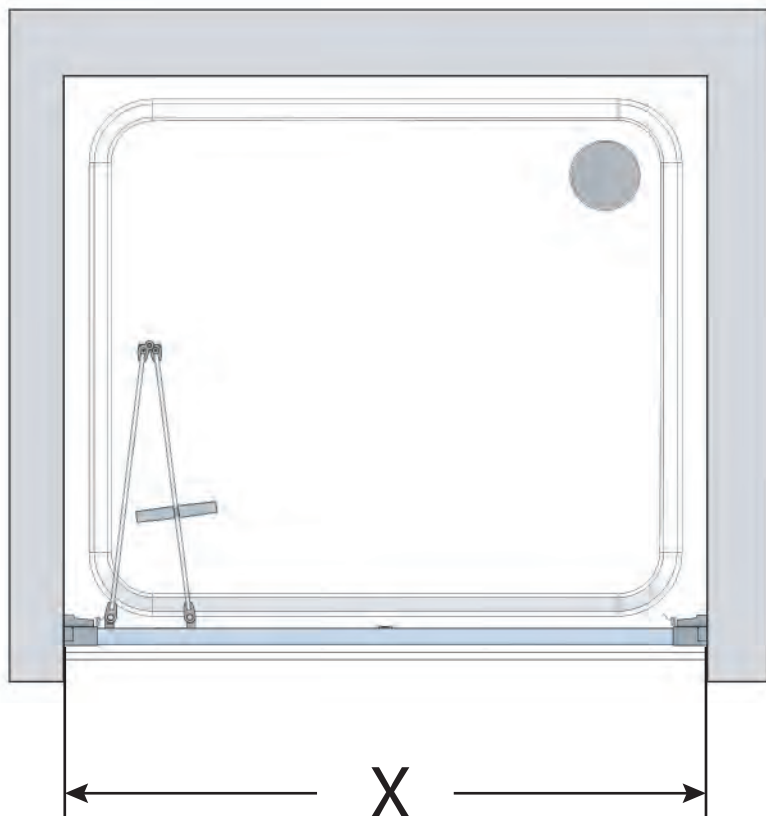

Product	Adjustment 'X'
WAVB070*	650 - 700
WAVB075*	700 - 750
WAVB080*	750 - 800
WAVB090*	850 - 900
WAVB100*	950 - 1000

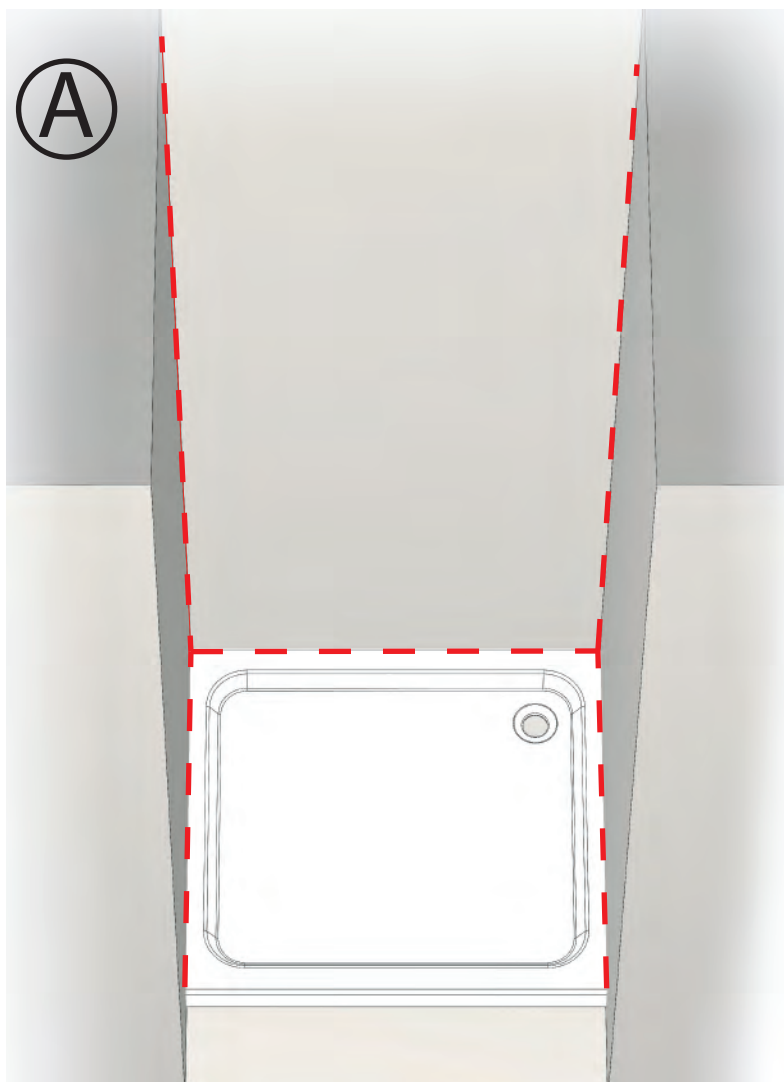

Lakes Wave Series Bifold Door is fully reversible so is suitable for fitting with door to left or right hand side of enclosure.

Ensure tray is correctly levelled & that tray / wall (tile) joints are sealed & cured over entire length of tray sides (See Fig A) prior to fitting enclosure.

DO NOT SEAL TRAY EDGES UP TO A FITTED ENCLOSURE !

Tools Required:

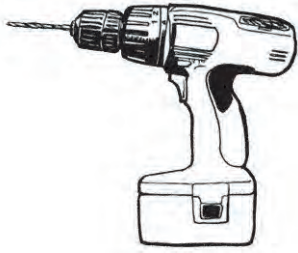

Power drill & 8mm masonry or tile bit



Spirit level



3mm HSS drill bit

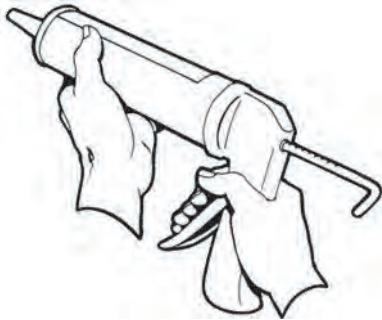

Good quality silicone sealant & applicator

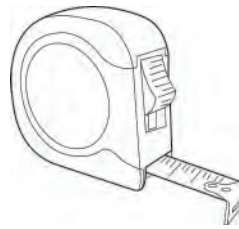

Tape measure

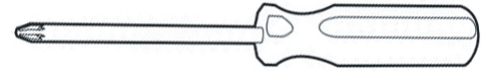

Pozi driv screwdriver



Pencil

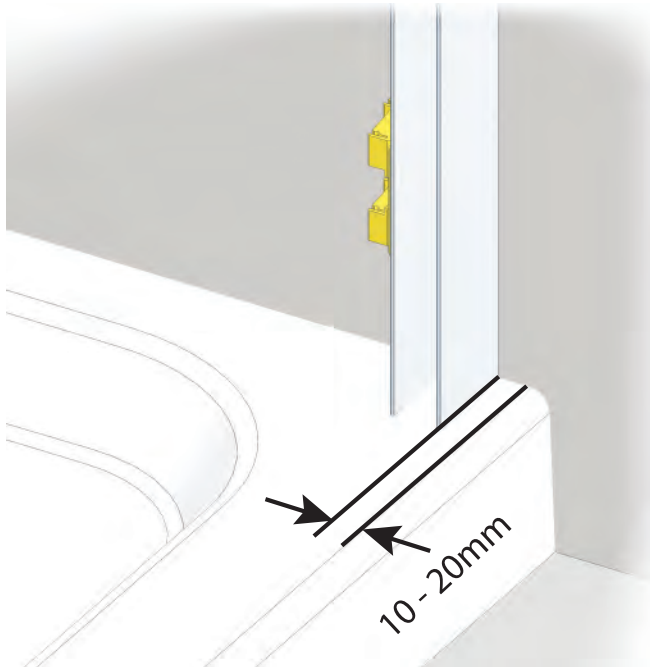

With outside of wall profile a minimum 10mm from the front of the tray and the flange facing towards the inside of the enclosure, make sure the profile is fully plumb & mark the centre of the 3 slots on the flange.

Drill marked positions with 8mm masonry or tile bit, plug holes & having decided on handing fix hinge side wall profile ONLY.

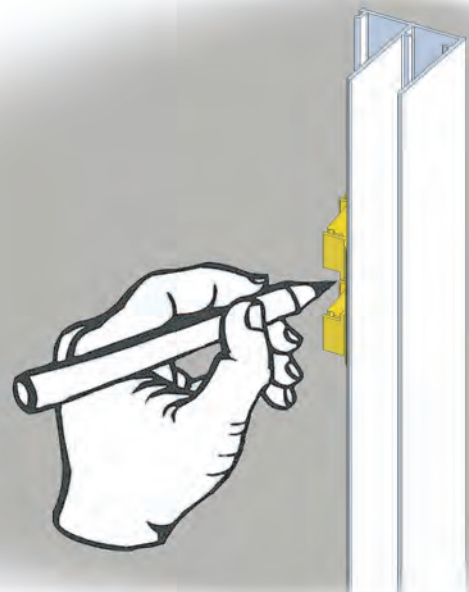



Push remaining wall profile onto opening side of frame and keeping unit upright, lift over tray rim &

1. Push hinge side into fixed wall profile.
2. Push opening side back into alcove. Align, plumb & fix using remaining wall plugs & 45mm screws.
3. Centralise door in wall profiles & ensure frame is plumb, door slides freely & magnets hold door in closed position.
4. From the inside of the enclosure, using the holes in the vertical profile as guides, drill using 3mm bit then fix using 10mm screws. (3 per side)

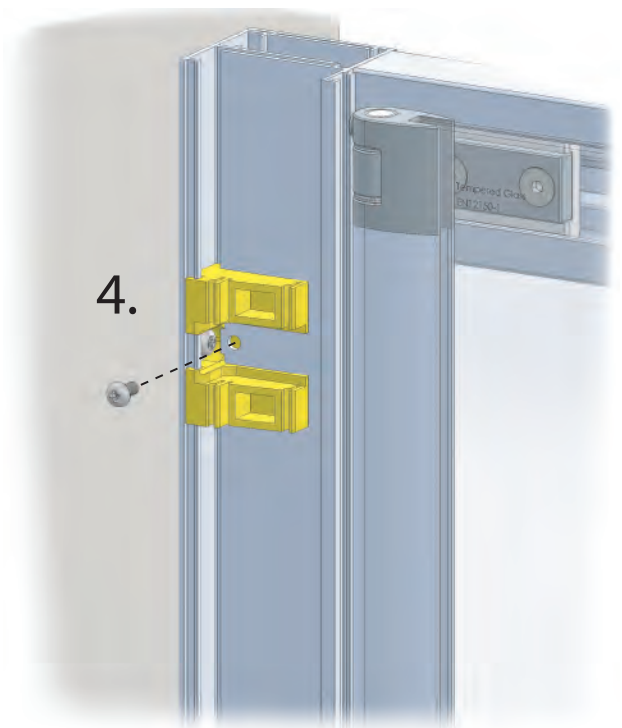

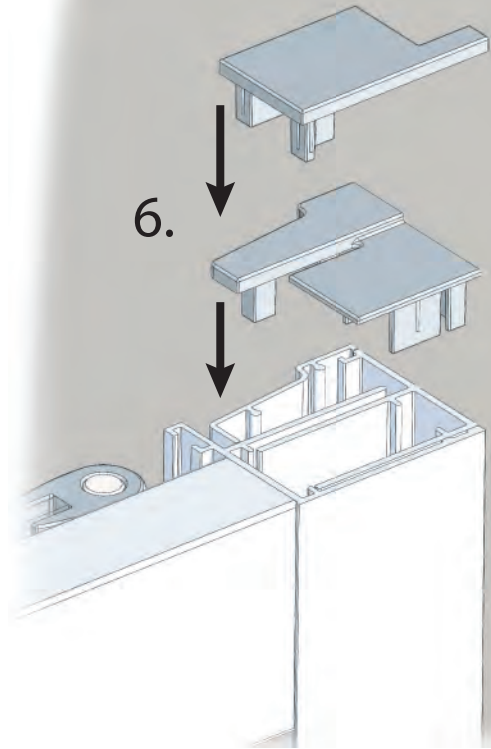
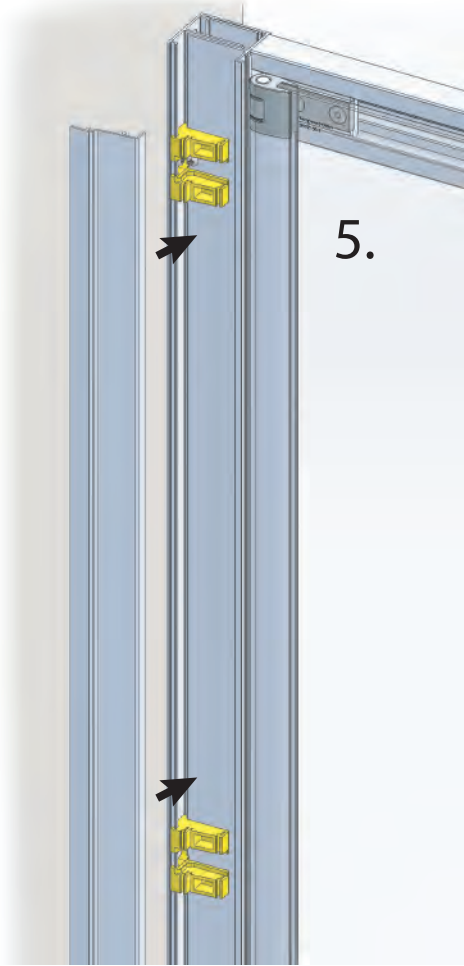

5. Push cover onto wall profile, ensuring all 5 clips are fully engaged.

6. Fit top caps in the order shown.

7. Fit handle to door with logo to front of enclosure.

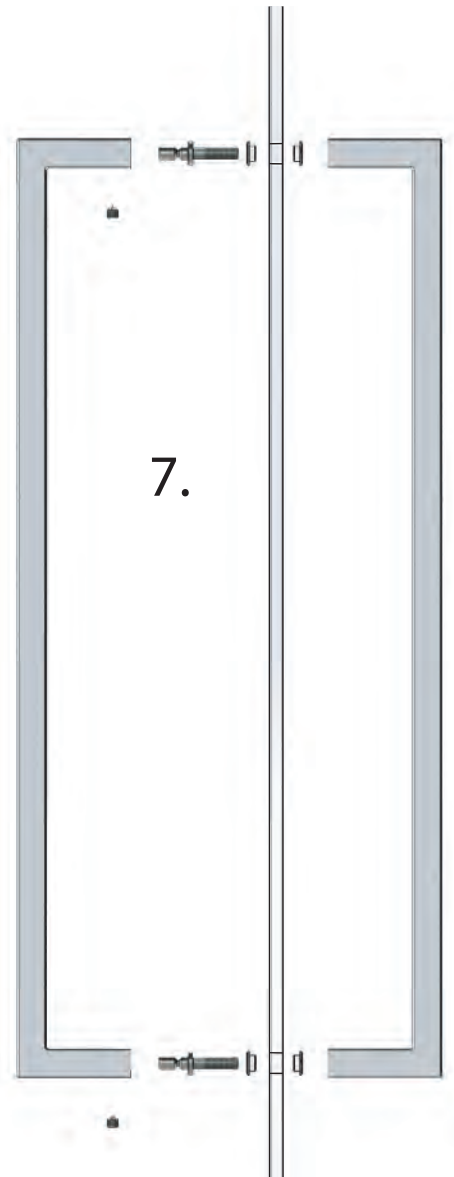

Apply a continuous bead of silicone sealant EXTERNALLY ONLY as shown.
Cleaning / degreasing of joints is highly recommended.
Use a good quality silicone sealant for best results.

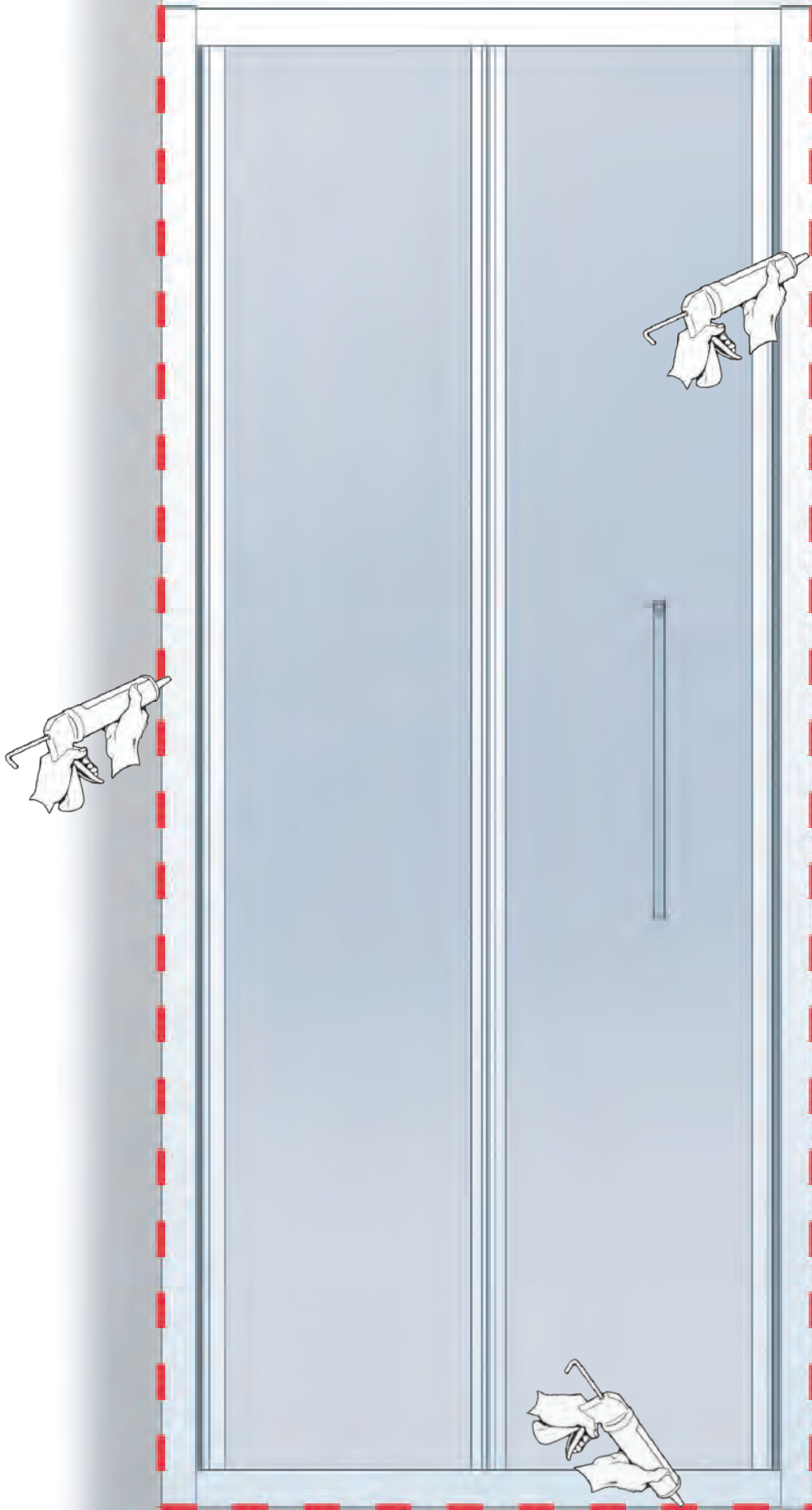

BASIC TROUBLESHOOTING :

Door magnetic seals not meeting precisely / not holding :

Check door alignments.

Check magnets in centre hinges for damage / omissions.

Door motion noisy / Door not running smoothly :

Check horizontal rails for debris / damage.

Check for lip seals dragging on frame and adjust door frame if necessary.

Leakage :

The sealing method described in these instructions relies on a continuous seal being applied between shower walls & tray before installing the enclosure (see fig A), it ensures a watertight seal around the perimeter of the enclosure to the shower walls & tray.

In the unlikely event of an enclosure leak, water will be visible on the outside of the enclosure itself, or around the perimeter silicone seal ONLY. Water / moisture appearing outside this area (i.e. at floor level) is normally due to incorrect tray installation.

Lakes Bathrooms Ltd.

Alexandra Way,

Ashchurch,

Tewkesbury,

Glos.

GL20 8NB

Service : England, Scotland & Wales

08:30 - 17:00 Mon. - Thurs.

08:30 - 16:30 Fri.

01684 857411

www.lakeshoweringspaces.com

info@lakeshoweringspaces.co.uk