

HORIZON - Hinged Bypass Panel

Installation / Maintenance Instructions

Rev 02.22



IMPORTANT NOTES :

Please Read Carefully & retain these instructions for Future Reference.

1. For ease & safety we advise that two persons assemble this product.
2. Protect shower tray surfaces at all times.
3. Exposed glass corners / edges **MUST NOT** contact hard surfaces at any time.
4. Check for cables, pipes etc before drilling walls.
5. Ensure all surfaces are dry, clean & free of loose debris / dust.
6. Unpack goods with care (small parts can become lodged in packaging & inadvertently discarded). Check parts supplied against parts & fittings listed herein. Damaged parts / omissions may be resolved by calling Lakes Bathrooms Helpline.
7. Whilst precautions are taken in manufacture, care must be taken when handling as rail ends may have sharp edges.
8. Before commencing, check :
 - a) shower tray (or base) is level & completely sealed to finished / tiled walls.
 - b) finished walls are sound & free of cracks, loose tiles / grout.
8. **AFTER INSTALLATION, DO NOT 'WET' ENCLOSURE FOR 48 HOURS TO ENSURE FULL CURE OF SILICONE SEALANT.**

USE :

General Care & Maintenance.

Provided this product is installed & operated in accordance with these instructions, problems should not arise. However should maintenance be required it should be carried out by a competent person with reference to these instructions. Before any work is carried out the root cause of the problem must be identified. Lakes Bathrooms service engineers are available if necessary to consult / carry out remedial work. Call Lakes Bathrooms HELPLINE.

Cleaning.

(Every one to two weeks depending on local water {hardness} conditions).

All glass panels in this product have a hydrophobic coating aiding 'runoff' of water droplets, reducing the need for frequent cleaning. For best appearance / product life however, regular cleaning is recommended.

Use **ONLY** mild soap / detergent solutions to clean. Rinse with water, squeegee glass panels & wipe frames dry with a soft cloth. Under no circumstances should abrasive, caustic or scouring products be used. Non compliance with these cleaning instructions may cause decorative finishes to deteriorate & could adversely affect safe operation of the enclosure.

Daily Care.

To prevent the build up of limescale, do not allow water droplets to dry on glass or frames. After showering, rinse with water, remove droplets from glass with a squeegee & wipe frame with a soft cloth.

Customer Service.

Quality Guarantee : Lakes Bathrooms Ltd guarantee Shower Doors & Enclosures against any manufacturing or material defects for the lifetime of the product. We will resolve defects free of charge by repairing / replacing parts as we feel necessary. To be 'free of charge' service work must be carried out by Lakes Bathrooms or approved agents.

Seals are considered 'wear & tear' parts, as such they are guaranteed for 12 months from purchase. Not Covered by this Guarantee : Damage or defects that result from improper installation, improper use, or lack of maintenance (including limescale buildup). Damage or defects that result from repairs / modifications undertaken by unauthorized persons. This guarantee is in addition to statutory & other legal rights.

What to do if something goes wrong : Should the product not function correctly on initial use, firstly, contact the installer to check that unit installation & commissioning are in accordance with these instructions. Should this not resolve difficulties or should performance decline, consult 'Troubleshooting' section to see if simple home maintenance is needed. Alternatively our HELPLINE staff can assist, or if necessary arrange for a service engineer to visit.

Spares : We maintain extensive spare part stocks. Spares can be ordered / purchased from your retailer in the first instance. Parts will normally be dispatched within two working days from order placement.

Supplied : Bypass assembly



comprising

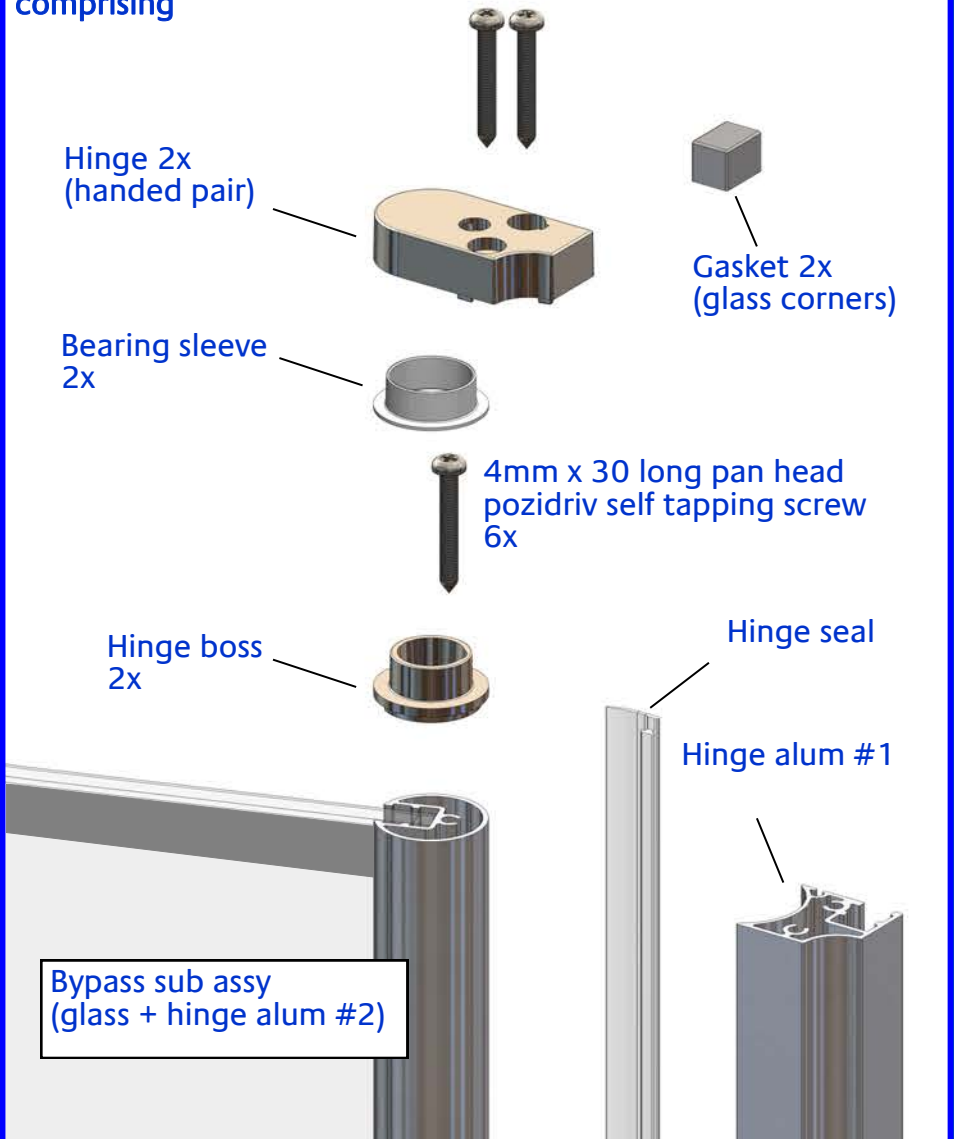

Tools Required



Spirit level (with vertical 'bubble') (recommended 1m minimum long)



Good quality CLEAR silicone sealant & applicator



Pozidriv screwdriver

Lakes Coastline hinge bypass is fully reversible so can be fitted to LH or RH products.
Installation may be carried out at same time as parent unit, OR at a later date.

(A)

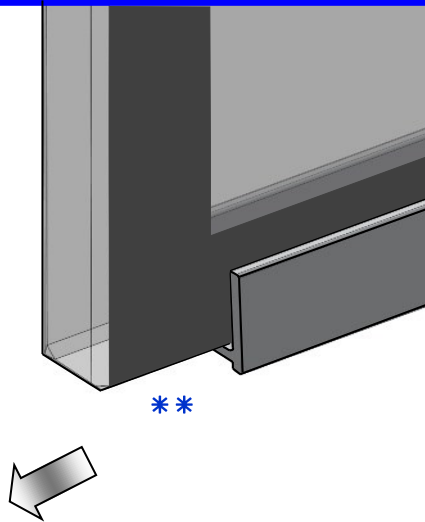
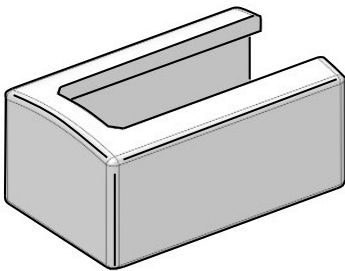

If already fitted, carefully cut silicone & remove the corner trim from bottom glass corner. Thoroughly clean & dry edge of glass, top to bottom. At this stage it is recommended to check that the bypass panel will fit to the glass edge - in particular check that bottom hinge & gasket fit beneath glass corner ** right upto the base trim

(B)

Glass corner gasket

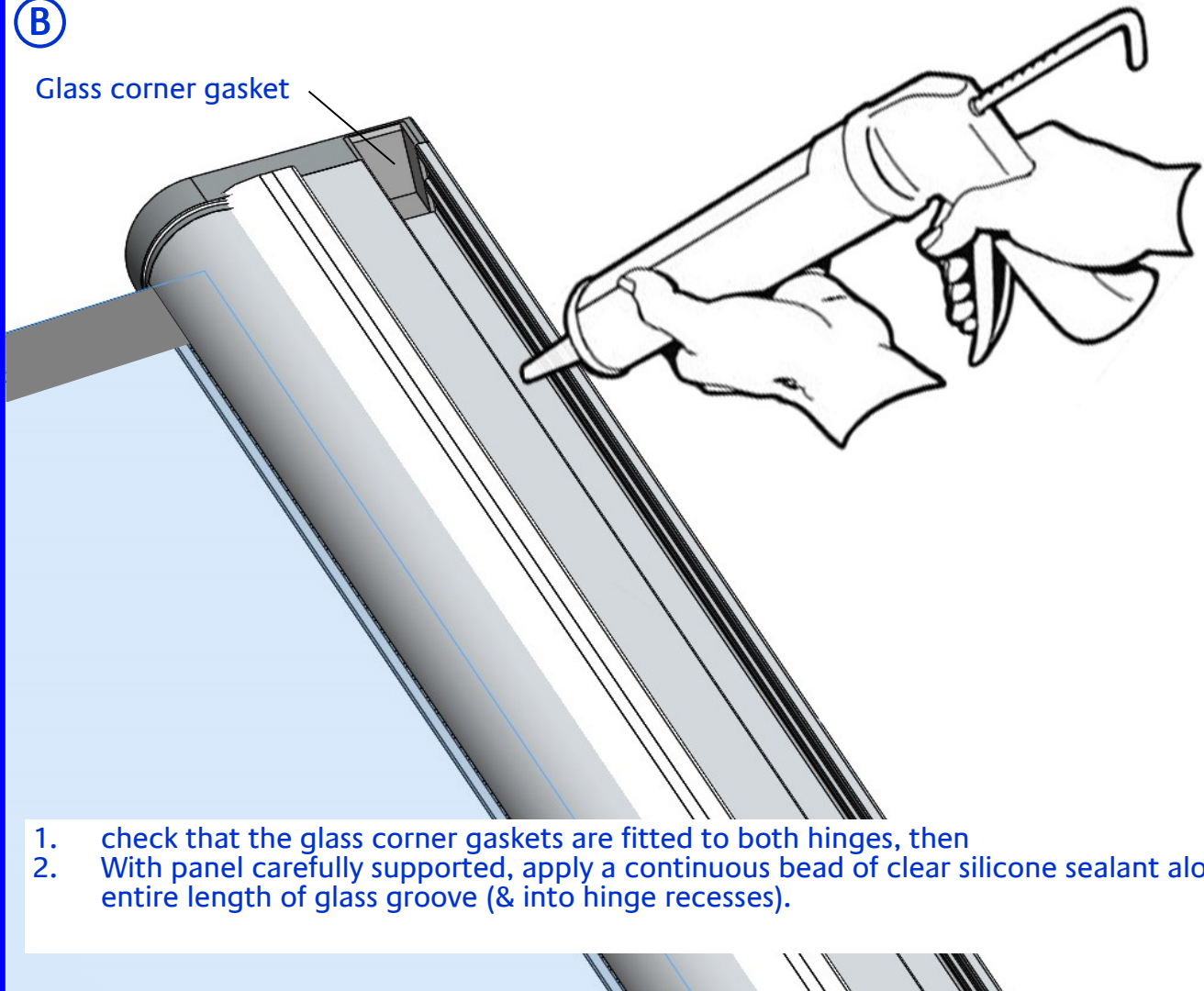

1. check that the glass corner gaskets are fitted to both hinges, then
2. With panel carefully supported, apply a continuous bead of clear silicone sealant along entire length of glass groove (& into hinge recesses).

©

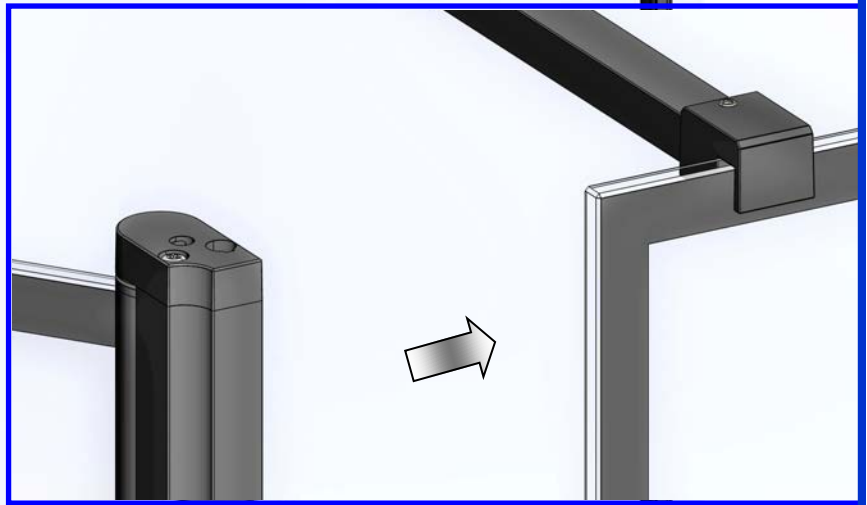

Align & push bypass assy onto glass edge firmly until aluminium is fully seated onto glass edge over entire height.
CHECK that alum #1 is completely straight using a long (1.5m) straight edge or spirit level.
If bow is present, the 'high' areas should be pressed further by hand, or using a block of wood for protection, may be 'knocked on' with a mallet or hammer until straight.
Check door motion is smooth & free of resistance.
Clean off ALL excess silicone sealant with a damp cloth or alcohol wipe.

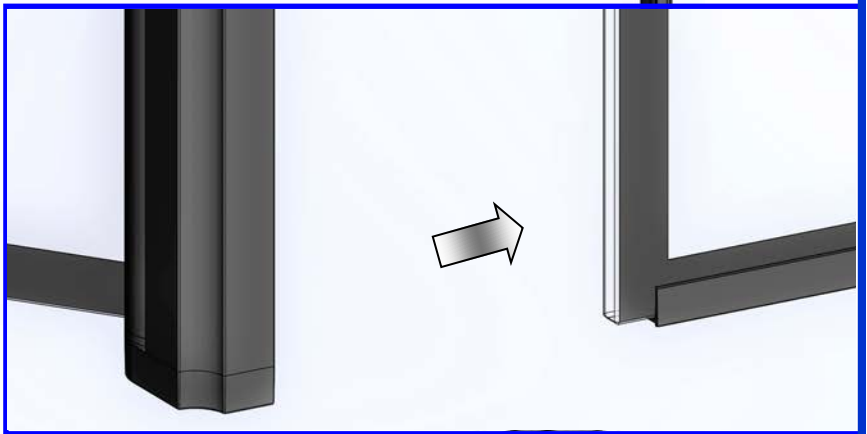

D

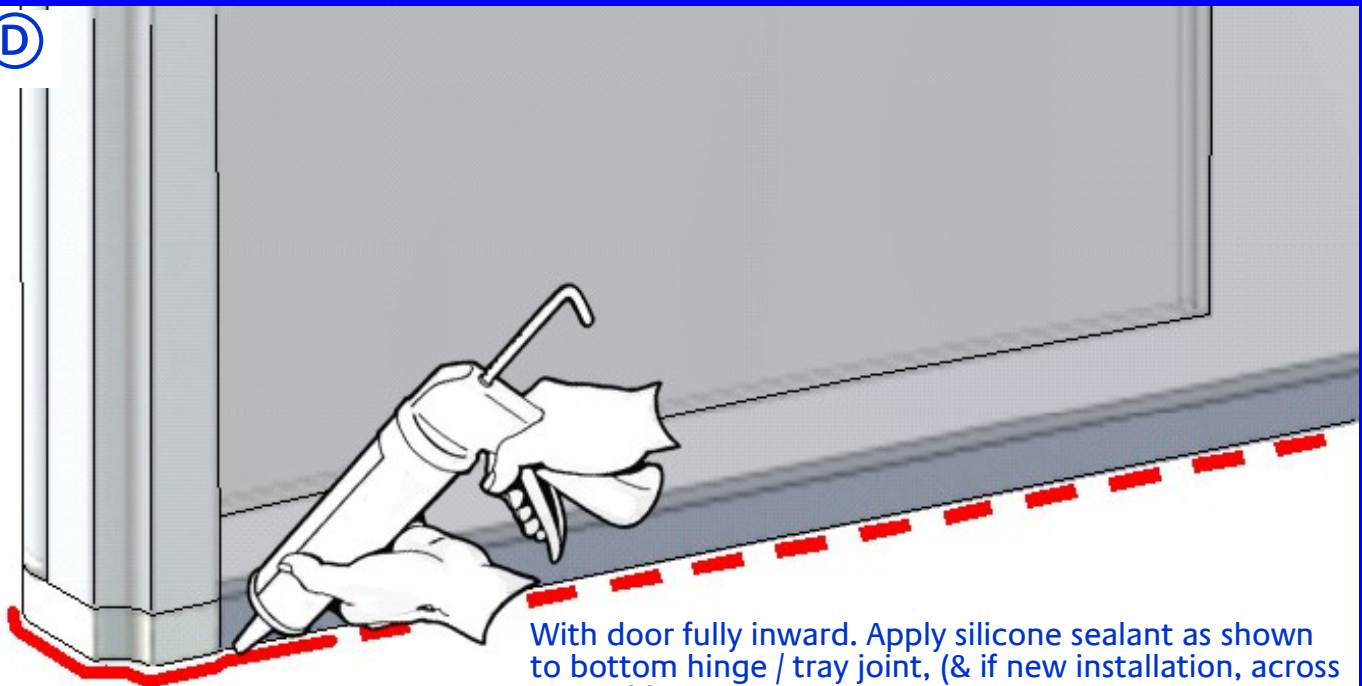

With door fully inward. Apply silicone sealant as shown to bottom hinge / tray joint, (& if new installation, across base of front panel as indicated). Leaving door inward, allow all silicone sealant joints to cure for 24hrs before using enclosure.

Basic troubleshooting :

Screen hinges noisy / not moving smoothly :

Apply sanitary silicone based grease to hinge bearing diameters.

Check that hinge seal is not distorted or trapped in gap between profiles.

Leakage : The sealing method described in these instructions relies on a continuous seal between walls & shower tray before installing the screen, in the unlikely event of a screen leak, water will be visible on the outside of the screen itself or around the perimeter silicone seal ONLY. Water / moisture appearing outside this area (ie at floor level or under shower tray) is normally due to incorrect tray / wall sealing.



Lakes Bathrooms Ltd

Alexandra Way
Ashchurch
Tewkesbury
Gloucestershire
GL20 8NB

Service England, Scotland, Wales

8.30am—5pm Mon ~ Thurs

8.30am—4.30pm Fri

Tel / HELPLINE : 01684 853870

Fax : 01684 857411

www.lakeshoweringspaces.com

Email : admin@lakeshoweringspaces.com

Service : Northern Ireland
Ian A Kernohan

Firtrees

Green Way Industrial Estate

Conlig

Northern Ireland

BT23 7SU

8.30am—5pm Mon ~ Thurs

8.30am—4.30pm Fri

Tel : 02891 270233

Fax : 02891 270597

Email : info@iakonline.com