

# COASTLINE Walk In Range

## Installation / Maintenance Instructions

Rev 01.19

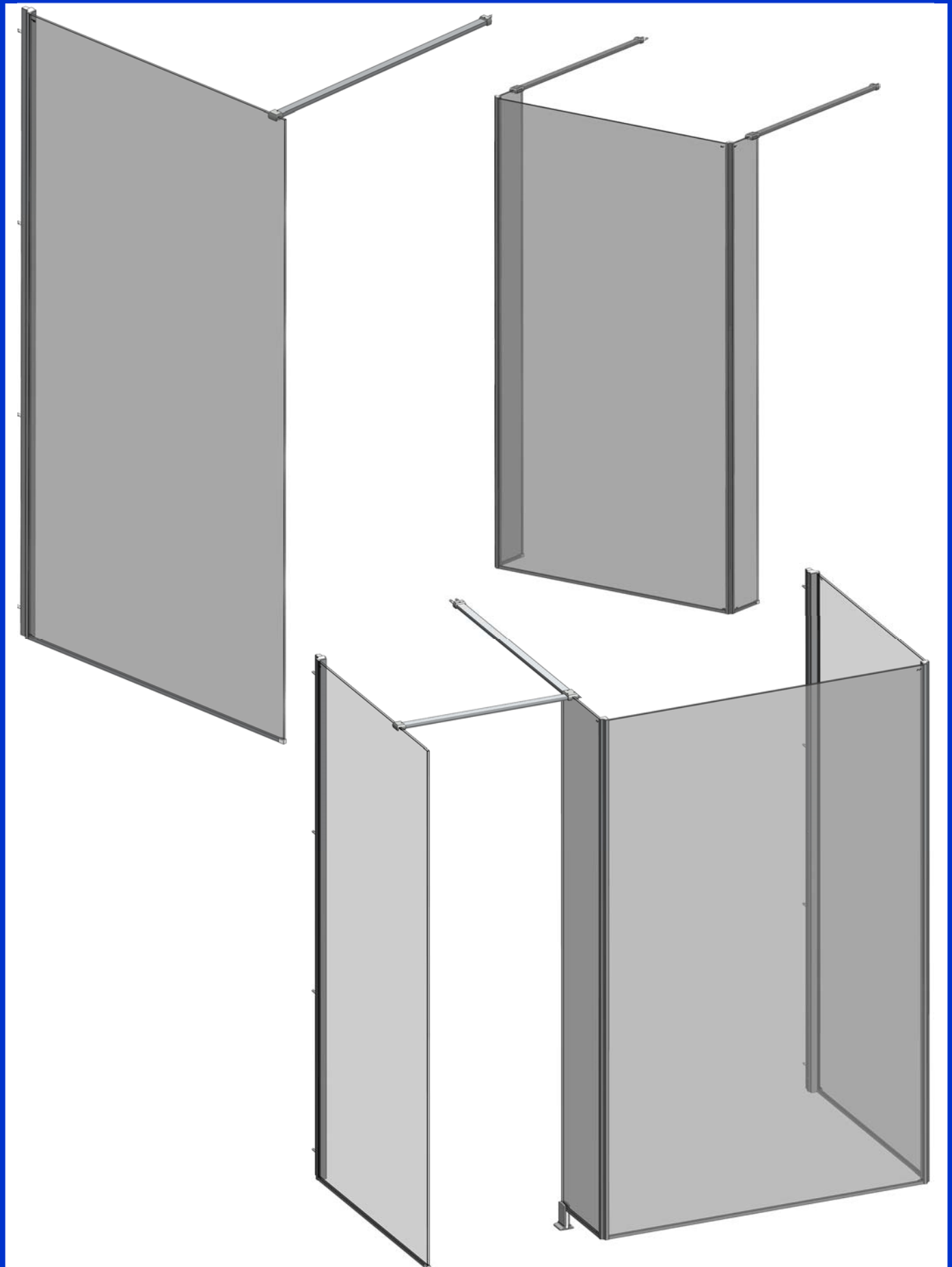

Typical variants shown, actual unit may differ in appearance.

## **IMPORTANT NOTES :**

Please Read Carefully & retain these instructions for Future Reference.

1. For ease & safety we advise that two persons assemble this product.
2. Protect shower tray surfaces at all times.
3. Exposed glass corners / edges MUST NOT contact hard surfaces at any time.
4. Check for cables, pipes etc before drilling walls.
5. Ensure all surfaces are dry, clean & free of loose debris / dust.
6. Unpack goods with care (small parts can become lodged in packaging & inadvertently discarded). Check parts supplied against parts & fittings listed herein. Damaged parts / omissions may be resolved by calling Lakes Bathrooms Helpline.
7. Whilst precautions are taken in manufacture, care must be taken when handling as rail ends may have sharp edges.
8. Before commencing, check :
  - a) shower tray (if used) is level & completely sealed to finished / tiled walls.
  - b) finished walls are sound & free of cracks, loose tiles / grout.
8. AFTER INSTALLATION, DO NOT 'WET' ENCLOSURE FOR 48 HOURS TO ENSURE FULL CURE OF SILICONE SEALANT.

## **USE :**

### **General Care & Maintenance.**

Provided this product is installed & operated in accordance with these instructions, problems should not arise. However should maintenance be required it should be carried out by a competent person with reference to these instructions. Before any work is carried out the root cause of the problem must be identified. Lakes Bathrooms service engineers are available if necessary to consult / carry out remedial work. Call Lakes Bathrooms HELPLINE.

### **Cleaning.**

(Every one to two weeks depending on local water {hardness} conditions).

All glass panels in this product have a hydrophobic coating aiding 'runoff' of water droplets, reducing the need for frequent cleaning. For best appearance / product life however, regular cleaning is recommended.

Use ONLY mild soap / detergent solutions to clean. Rinse with water, squeegee glass panels & wipe frames dry with a soft cloth. Under no circumstances should abrasive, caustic or scouring products be used. DO NOT use 'spray & leave' type cleaning products. Non compliance with these cleaning instructions may cause decorative finishes to deteriorate & could adversely affect safe operation of the enclosure.

Limescale ~ should a build up of limescale occur, remove using a 50:50 solution of white vinegar & water applied with a soft cloth & rinsed / dried thoroughly afterwards.

### **Daily Care.**

To prevent the build up of limescale, do not allow water droplets to dry on glass or frames. After showering, rinse with water, remove droplets from glass with a squeegee & wipe frame with a soft cloth.

### **Customer Service.**

Quality Guarantee : Lakes Bathrooms Ltd guarantee Shower Doors & Enclosures against any manufacturing or material defects for the lifetime of the product. We will resolve defects free of charge by repairing / replacing parts as we feel necessary. To be 'free of charge' service work must be carried out by Lakes Bathrooms or approved agents.

Not Covered by this Guarantee : Damage or defects that result from improper installation, improper use, or lack of maintenance (including limescale buildup). Damage or defects that result from repairs / modifications undertaken by unauthorized persons. This guarantee is in addition to statutory & other legal rights.

What to do if something goes wrong : Should the product not function correctly on initial use, firstly, contact the installer to check that unit installation & commissioning are in accordance with these instructions. Should this not resolve difficulties or should performance decline, consult 'Troubleshooting' section to see if simple home maintenance is needed. Alternatively our HELPLINE staff can assist, or if necessary arrange for a service engineer to visit.

Spares : We maintain extensive spare part stocks. Spares can be ordered / purchased from your retailer in the first instance. Parts will normally be dispatched within two working days from order placement. Pro Forma invoices will be sent for cheque payments.

## MODELS

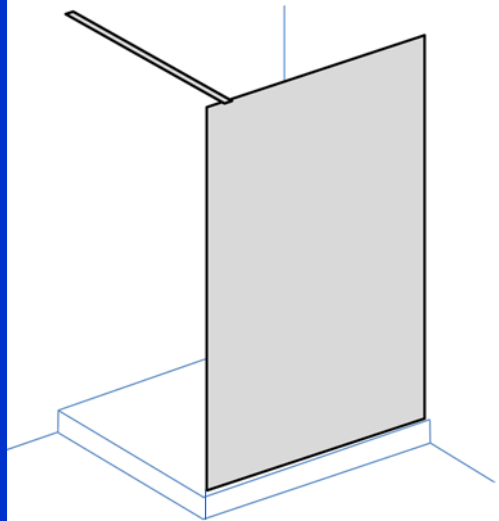

**Cannes  
(or Side Panel)**

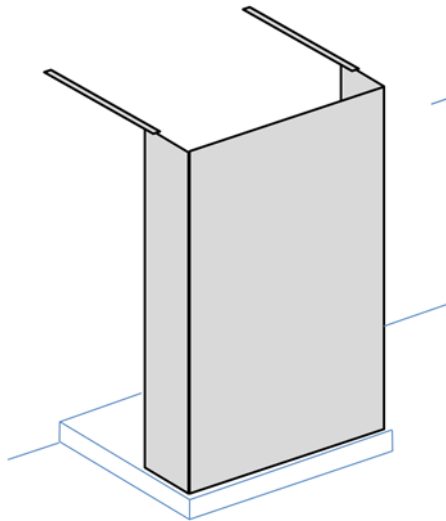

**Riviera  
(Riviera \*)**

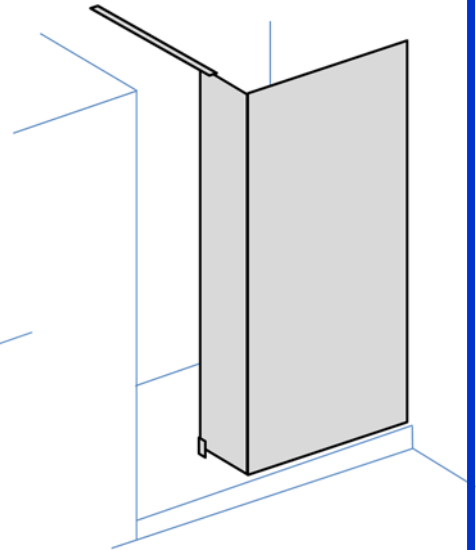

**Nice**

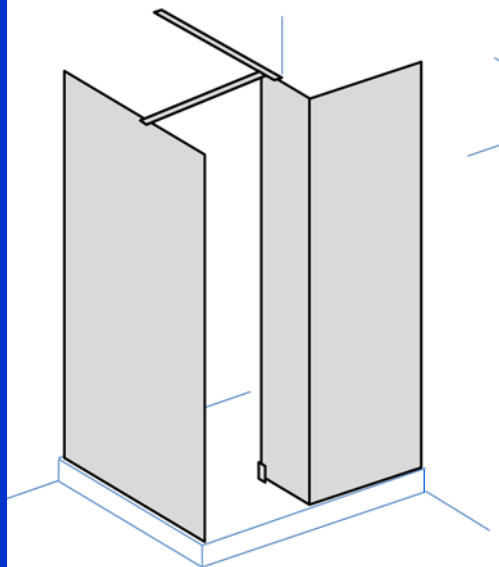

**Palma**

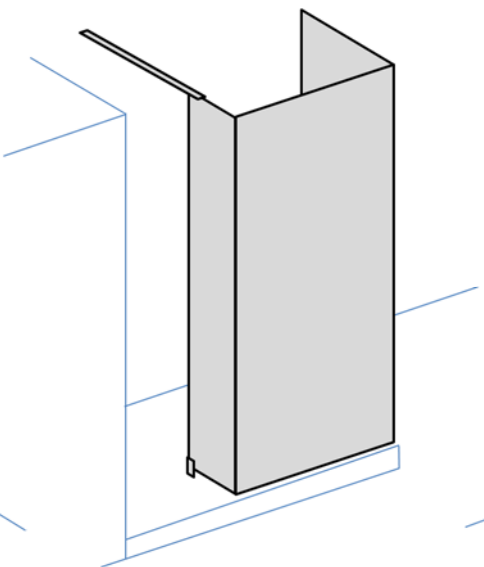

**Andora**

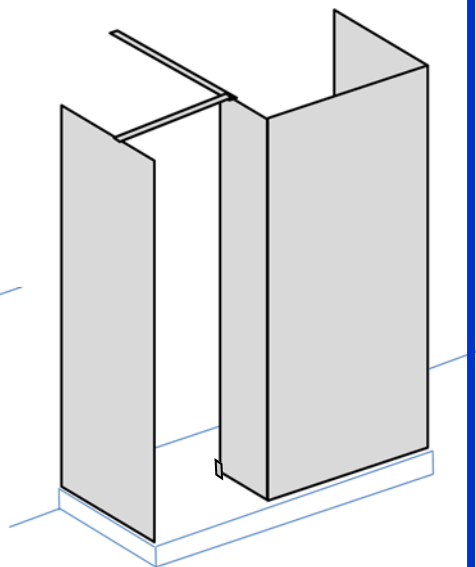

**Rhodes**

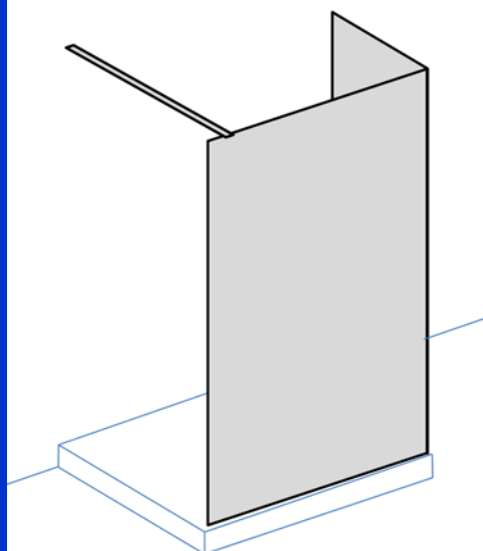



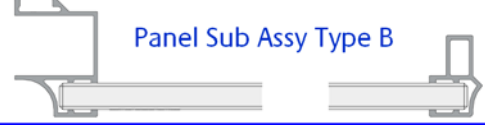
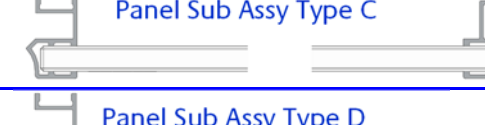
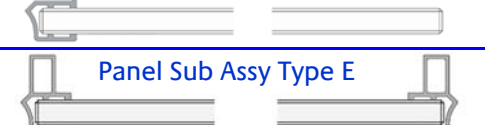
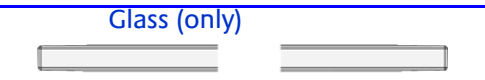
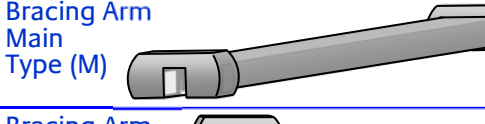

**Marseilles**

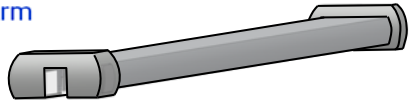
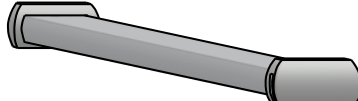

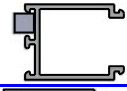
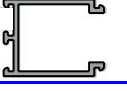
Unit	Comprises	Cartons
Cannes	LK810	1
Riviera	LK811	3
Riviera *	LK819	1
Nice	LK812	2
Palma	LK812 + LK810	3
Andora	LK814 + LK818	3
Rhodes	LK814 + LK818 + LK810	4
Marseilles	LK815 + LK818	2

Supplied Parts :	LK810	LK811	LK812	LK814	LK815	LK818	LK819
 Panel Sub Assy Type A	1x						
 Panel Sub Assy Type B			1x			1x	
 Panel Sub Assy Type C				1x			
 Panel Sub Assy Type D		2x	1x	1x	1x		
 Panel Sub Assy Type E		1x					
 Glass (only)							1x

 Bracing Arm Main Type (M)		2x	1x	1x			
 Bracing Arm Screen Type (S)	1x				1x		2x

 Wall Profile (with Foam Seal) 2m long	1x		1x			1x	
 Extension Profile optional fit 2m long	1x		1x			1x	
 Bottom Trim lengths to suit panels	1x	5x 3 used	3x 2 used	3x 2 used	1x	1x	1x
 Cover Profile 2m long	1x	2x	2x	2x	1x	1x	
 Foot Kit (Bypass Panel)			1x	1x			

#### General Fixings \*\*

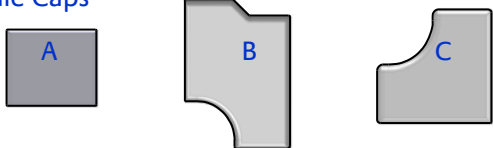
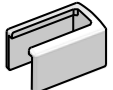
 Wall Screws / Plugs	4x each		4x each			4x each	
 Joining Screws	3x	6x	6x			9x	
 Profile Caps A B C	A 2x B pair C -	A - B - C 2x	A 2x B pair C 1x			A 2x B pair C 2x	
 Bottom Trim End Cap	1x	2x	1x			1x	2x

\*\*Ref General Fixings ~ surplus parts may be present, quantities stated are minimum requirements per product & additional items required for 'handing'.

Used in conjunction with 18

## Tools Required

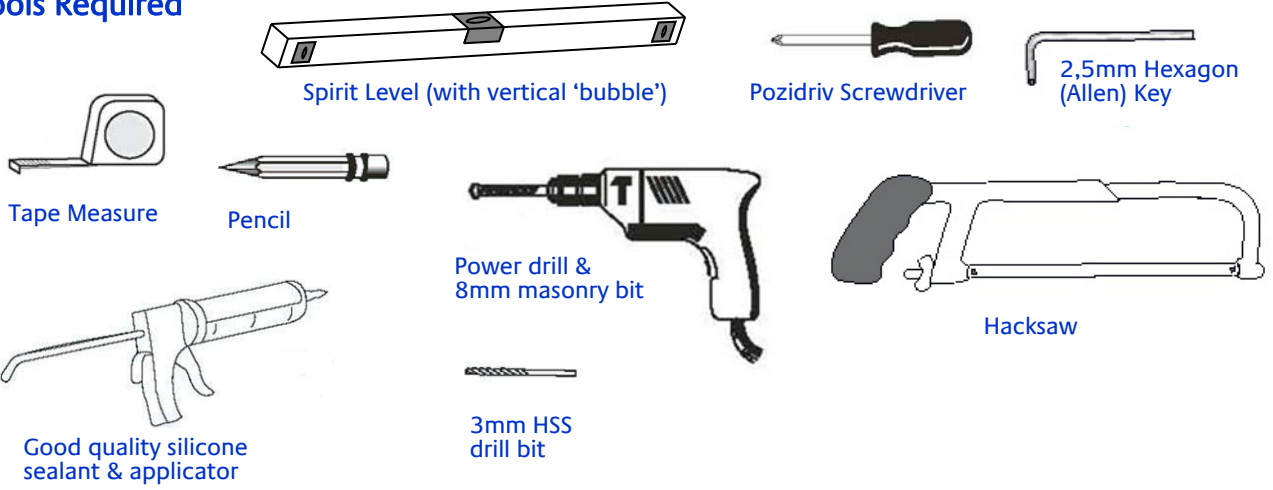

Lakes Coastline Walk In enclosures are fully reversible. Versatile construction permits their use onto a wide range of base footprints, tray or wetroom installations. Ensure tray / floor is level & that all base / wall joints are sealed & cured over entire length of sides (See Fig A) prior to fitting enclosure.

**A** Setting Out : **Fitting to Tray** ~ To ensure enclosure is situated entirely on the flat surface of the tray rim, wall profiles should be mounted a minimum of 18mm inboard of tray edges. **Wetroom** ~ Enclosure may be sited as desired in relation to wet area (within size range of product).

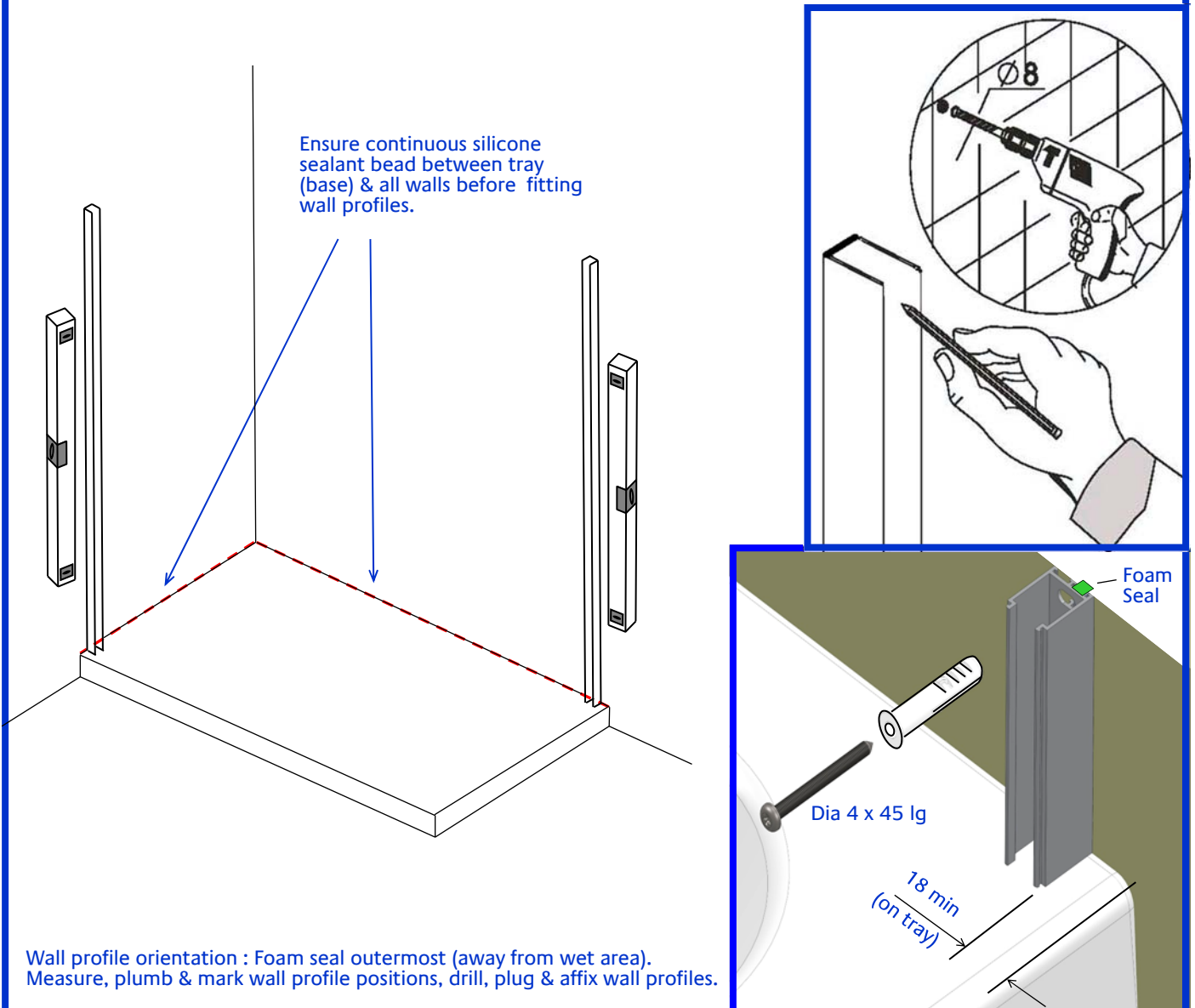

## Select Hand ~ Fit bottom trims

Select 'hand' for unit build. Trims are fitted at base only. Apply a continuous bead of silicone along inside of trim then carefully push trims fully onto bottom edges of glass panels. Butt trims up to vertical profiles (centre on 819). Do not bend or strike with hard objects, a soft mallet or hammer & wooden block should be used. Select appropriate bottom trim for bypass panel (with / without foot ~ see table).



(B)

## Typical Wall Panel Construction :

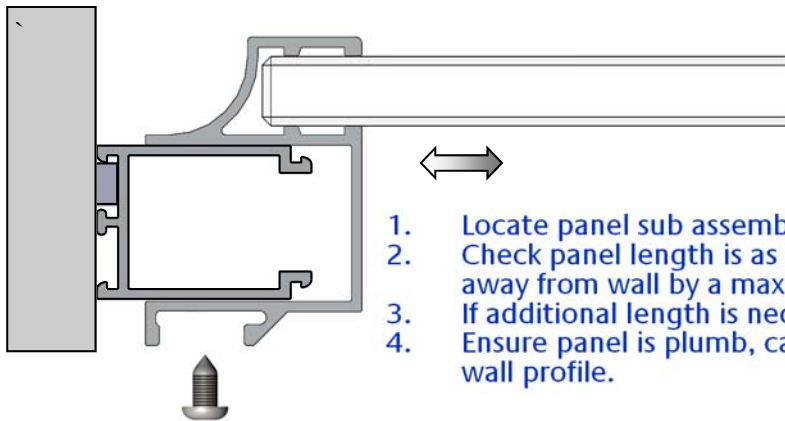

1. Locate panel sub assembly onto wall profile & push back to wall.
2. Check panel length is as desired / required (panel may be pulled away from wall by a maximum of 15mm).
3. If additional length is necessary see below.
4. Ensure panel is plumb, carefully drill (dia 3mm) & screw panel to wall profile.

By-pass Size	Bottom Trim Length	
	With Foot	Without Foot
200	138	161
320	258	281
400	335	358

## Typical extended Panel Construction :

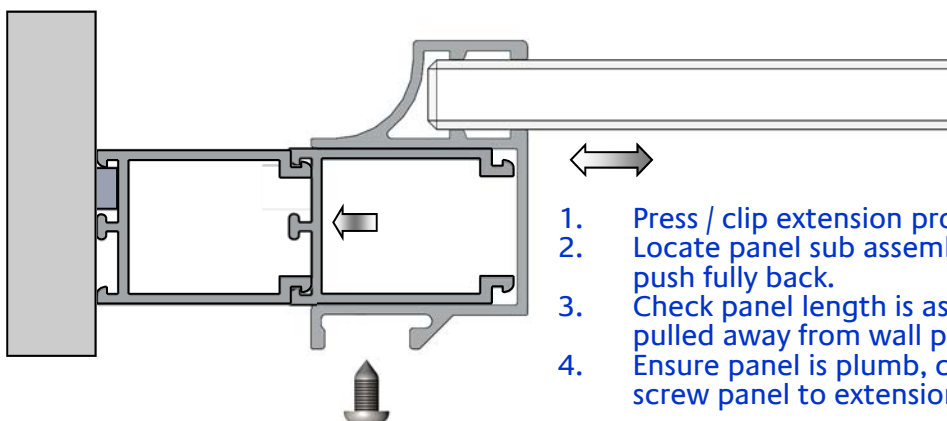

1. Press / clip extension profile onto wall profile.
2. Locate panel sub assembly onto extension profile & push fully back.
3. Check panel length is as required (panel may be pulled away from wall profiles by 15mm).
4. Ensure panel is plumb, carefully drill (dia 3mm) & screw panel to extension profile.

## Typical Corner Construction :

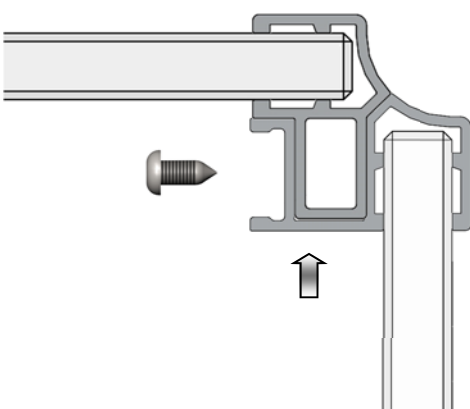

Corner Profiles to be pushed & held together firmly during fixing. Ensure both panels are plumb & top edges are aligned. Carefully drill (dia 3mm) & screw corner profiles together.

## Typical Corner piece assembly :

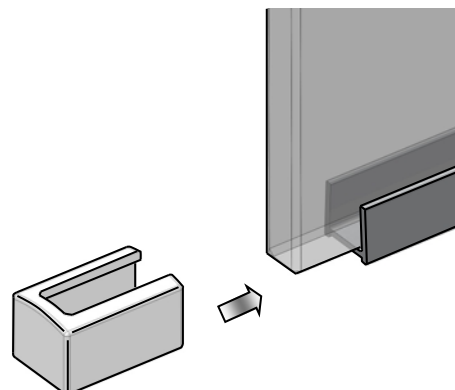

'Fit corner piece to bottom corner of 'open' glass edges. Clear silicone may be used to retain ~ wipe off excess. If a foot is to be used, see Foot Kit instructions (Fig C)

**Foot Kit : (Models 812 & 814 Bypass Panel ~ Over Tray Recess Mounted).**



1. With unit supported in position & plumb, measure gap between bottom of bypass glass & tray surface.

2. Using scale, cut spacer to measured size.

3. Refit spacer into foot, apply 'blob' of silicone sealant to base of foot assy. Push foot fully onto glass corner (moisten glass corner to ease fit if necessary). Press bypass panel & foot down onto tray surface & wipe off excess sealant with a damp cloth.

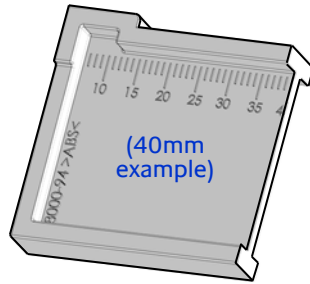
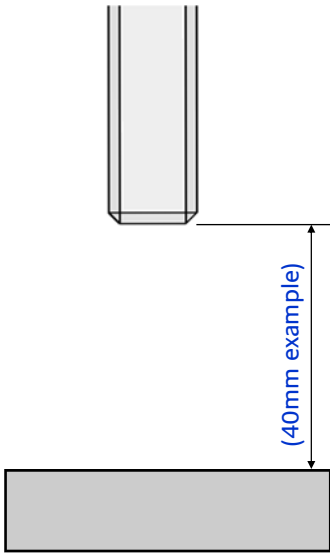

Note : actual length will be 3mm less than indicated by scale.

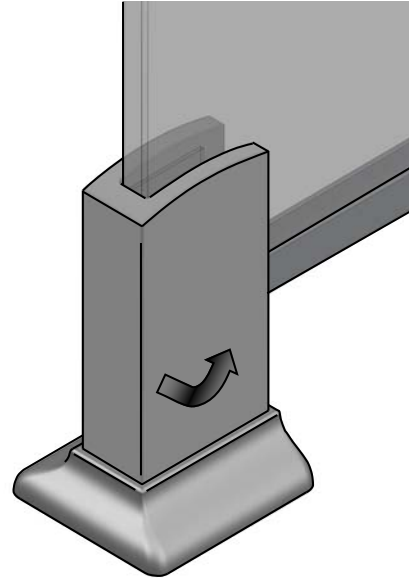

**Bracing Kits : Main, Screen & Side Panel types.**

With unit in desired position, (check panels are plumb & parallel / square to tray sides) measure distance indicated & cut bar(s) to appropriate length (& deburr) as follows :

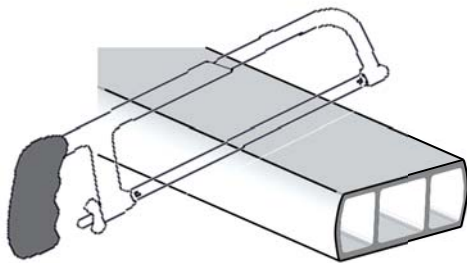

NOTE : Main (M) type :  
Cut ONLY from non slotted end !

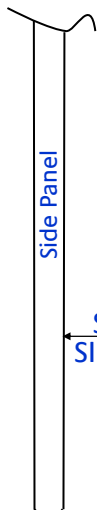

SP ~ Cut bar to SP - 7mm  
SIDE PANEL type bracing bar  
(810)



M ~ Cut bar to M + 14mm  
MAIN type bracing bars  
(811, 812, 814)

Front Panel

S ~ Cut bar to S - 10mm  
SCREEN type bracing  
(810, 815, 819)

Front Panel



## Bracing (continued.)

(D)

Assemble bracing bar(s) onto enclosure ; do not tighten clamps at this time. Lightly mark bracket positions on panels. Align / plumb & mark wall bracket hole positions, drill, plug & mount wall bracket.

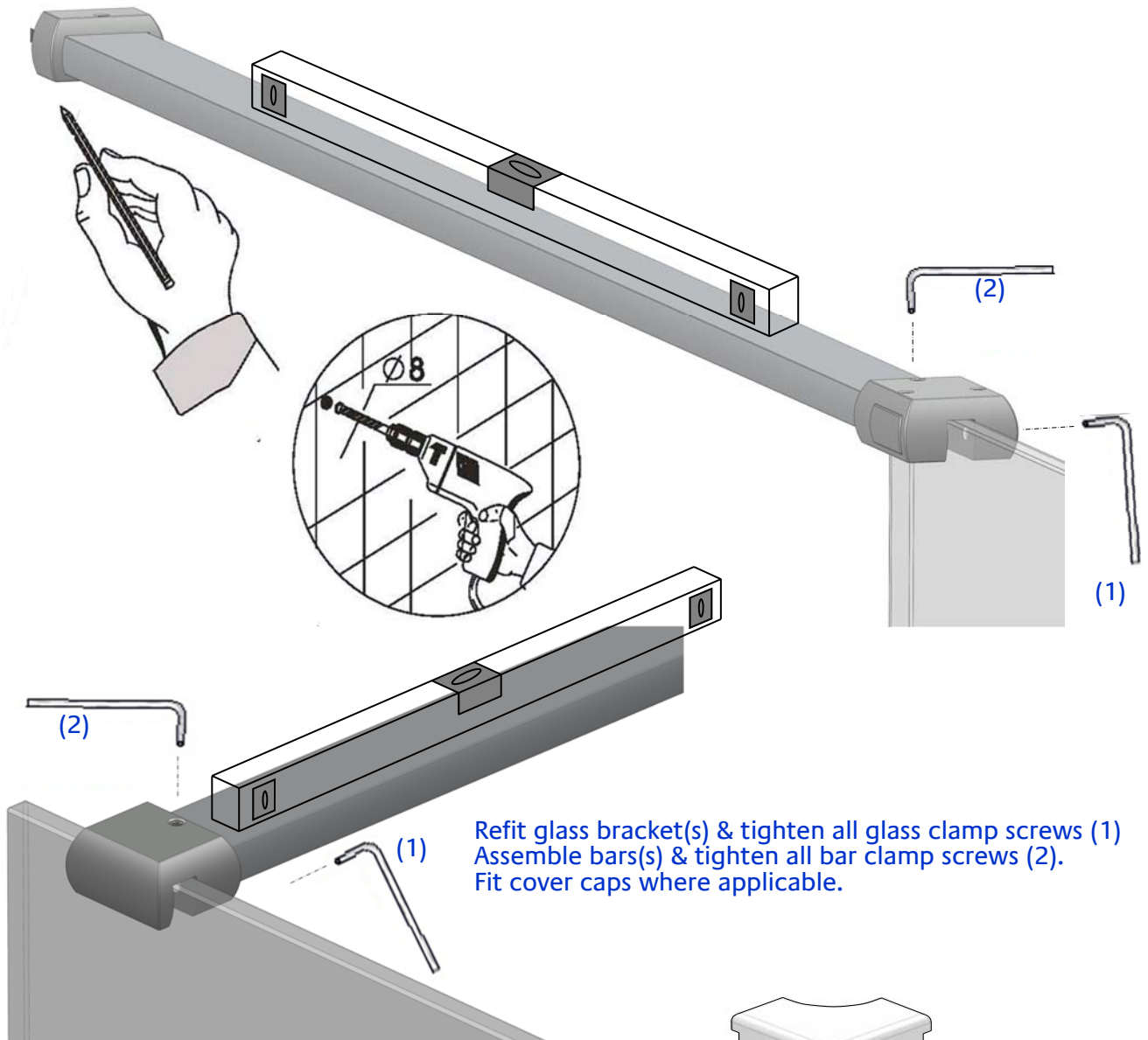

Refit glass bracket(s) & tighten all glass clamp screws (1)  
Assemble bars(s) & tighten all bar clamp screws (2).  
Fit cover caps where applicable.

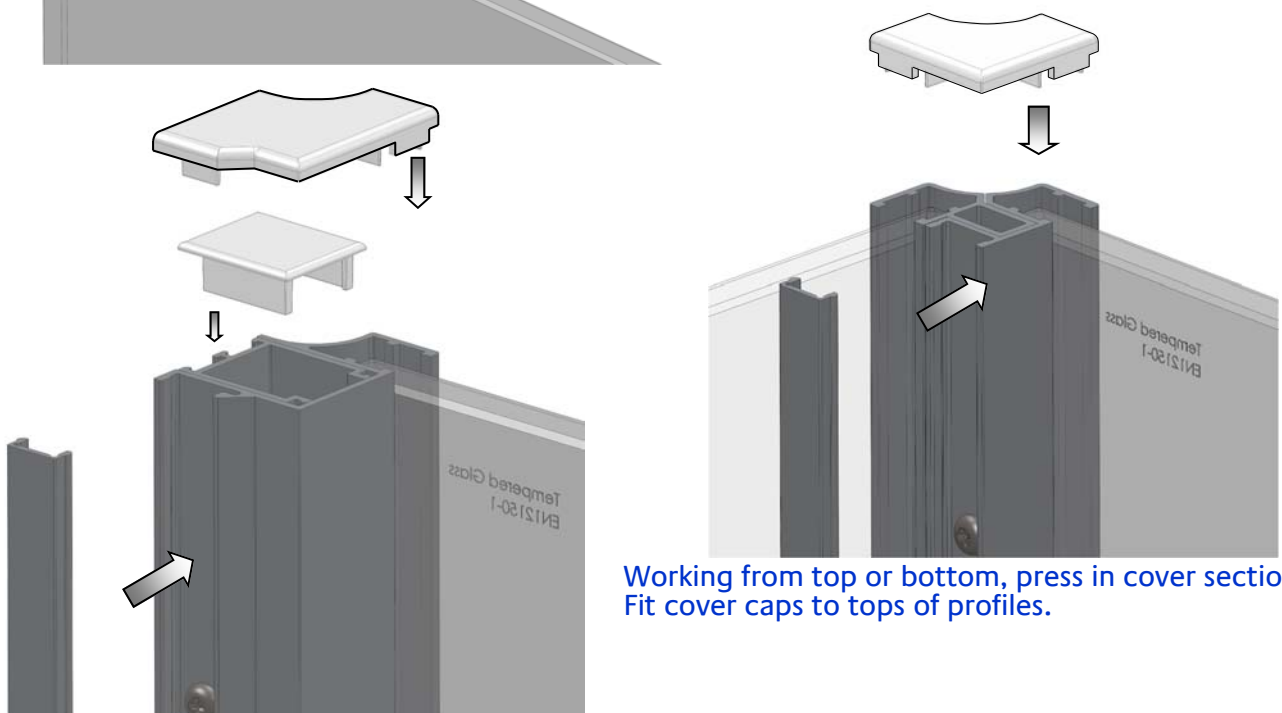

Working from top or bottom, press in cover section(s).  
Fit cover caps to tops of profiles.



SEALING :

Ⓔ

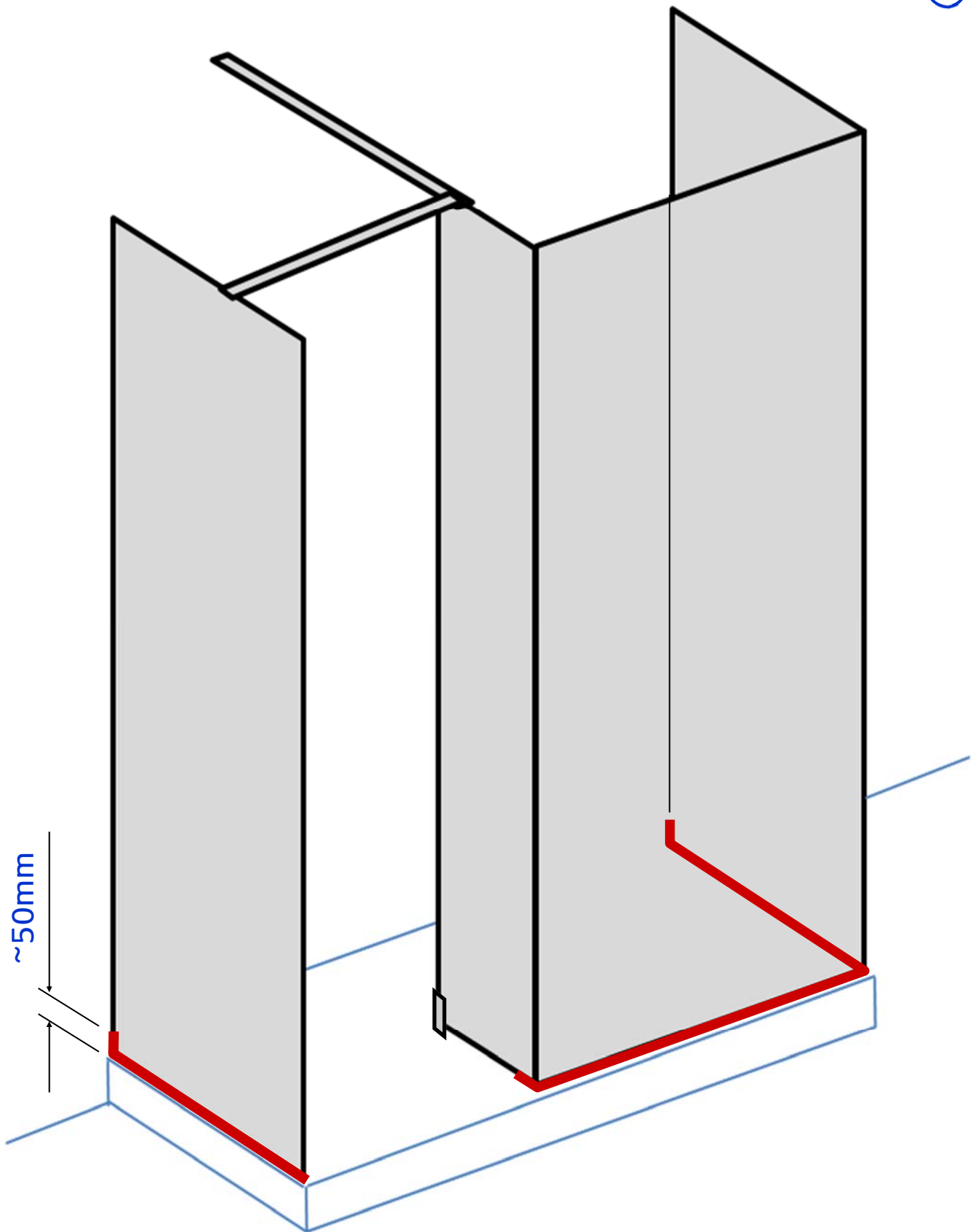

Use of good quality silicone sealant & cleaning / degreasing of all joint areas is recommended.

Apply continuous silicone sealant bead EXTERNALLY ONLY to all panels in contact with tray rim / floor & vertically approx 50mm (2") between wall & wall profile.

## **BASIC TROUBLESHOOTING :**

### **Leakage :**

The sealing method described in these instructions relies on a continuous seal being applied between shower walls & tray before installing the enclosure (see fig A), it ensures a watertight seal around the perimeter of the enclosure to the shower walls & tray.

In the unlikely event of an enclosure leak, water will be visible on the outside of the enclosure itself, or around the perimeter silicone seal ONLY. Water / moisture appearing outside this area (ie at floor level) is normally due to incorrect tray installation.

The foam seal provided on the wall profile will tolerate most grouted joints. If excessively deep joints are present, & leakage does occur, additional silicone sealant may be applied over full length of wall profile / wall joints.

### **Lakes Bathrooms Ltd**

Alexandra Way  
Ashchurch  
Tewkesbury  
Gloucestershire GL20 8NB

Service England, Scotland, Wales

8.30am—5pm Mon ~ Thurs  
8.30am—4.30pm Fri  
Tel / HELPLINE : 01684 853870  
Fax : 01684 857411  
www.lakesbathrooms.co.uk  
Email : admin@lakesbathrooms.co.uk

Service : Northern Ireland  
Ian A Kernohan  
Firtrees  
Green Way Industrial Estate  
Conlig  
Northern Ireland  
BT23 7SU

8.30am—5pm Mon ~ Thurs  
8.30am—4.30pm Fri  
Tel : 02891 270233  
Fax : 02891 270597  
Email : info@iakonline.com